

# 5FHDA

## FEMA Louver | Chevron Blade FEMA 361 Grille

UL Listed



### APPLICATION

The 5FHDA is a stationary extreme weather louver with sightproof blades. This louver is tested to FEMA 361 standard design and ICC500 specification for large missile impact and can be mounted internally, externally or in conjunction with other louvers with a 5" deep frame.

### STANDARD CONSTRUCTION

Frame	2" x 5 1/2" x 2" (51 x 140 x 51) channel 1/4" (6) Thick Extruded Aluminum.
Blades	3" x 3" x 1/4" (75 x 75 x 6) Thick Chevron Style Extruded Aluminum.
Bird Screen	5/8" x .040" (16 x 1) expanded flattened aluminum bird screen in removable frame. Screen adds approximately 1/2" (13) to louver depth. Screen required to meet spawlling component to FEMA 361 standards.
Finish	Mill.
Minimum Size	12"w x 12"h (305 x 305).
Approximate Shipping Weight	13 lbs. per sq. ft. (193.5 kg/m <sup>2</sup> ).
Maximum Shipping Section Size	For 300 psf 48"w x 78"h (1220 x 1982). For 230 psf 48"w x 90"h (1220 x 2286). For 200 psf 48"w x 96"h (1220 x 2439).
Maximum Overall Assembly Size	Unlimited width x one section tall.

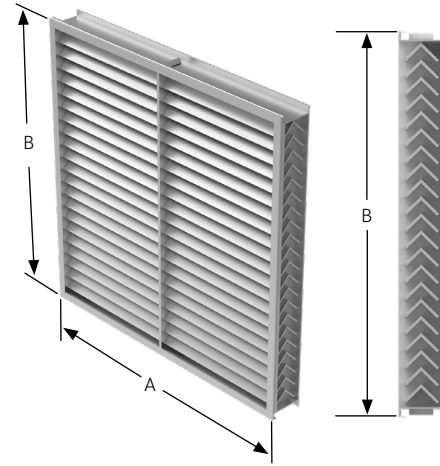

### FEATURES

- Louver complies with FEMA 361 Design and Construction for Community Shelters, Zone IV criteria, 250 MPH wind, 15 lb. 2 x 4 impact at 100 mph for tornadoes
- Louver complies with FEMA 361 Design and Construction for Community Shelters, Zone IV criteria, 230 MPH wind, 15 lb. 2 x 4 impact at 100 mph for Hurricanes
- Louver mounted externally in combination with wall louver or by itself internally
- 50% Free Area
- Tested to ICC500 (2020), FEMA Guideline P-361 (2021) FEMA Guideline -320 (2014)
- This product is listed to applicable UL Standards and Requirements

### VARIATIONS

Variations to the basic design of this louver are available at additional cost. They include:

- Extended sill
  - Blank off panels
  - Frame caps
  - Optional finishes available at additional cost. Please see [Paint Finishes and Color Guide](#) and [Finish Type Model Chart](#) for more details. Contact [louversales@reliable.com](mailto:louversales@reliable.com) with questions
  - Variety of screens and locations
- Consult Reliable for other special requirements.

#### NOTES:

- Dimensions in inches, parenthesis ( ) indicate millimeters
- Units can be furnished actual size or with sizes deducts

## FREE AREA GUIDE

Free Area Guide shows free area in ft<sup>2</sup> and m<sup>2</sup> for various sizes of 5FHDA.

		Width – Inches and Meters						
		12 0.30	18 0.45	24 0.60	30 0.75	36 0.90	42 1.05	48 1.20
Height – Inches and Meters	12 0.30	<b>0.28</b> 0.03	<b>0.46</b> 0.04	<b>0.64</b> 0.06	<b>0.83</b> 0.08	<b>1.01</b> 0.09	<b>1.20</b> 0.11	<b>1.38</b> 0.13
	18 0.45	<b>0.49</b> 0.05	<b>0.81</b> 0.08	<b>1.13</b> 0.11	<b>1.46</b> 0.14	<b>1.78</b> 0.17	<b>2.10</b> 0.20	<b>2.42</b> 0.23
	24 0.60	<b>0.76</b> 0.07	<b>1.27</b> 0.12	<b>1.77</b> 0.16	<b>2.27</b> 0.21	<b>2.78</b> 0.26	<b>3.28</b> 0.31	<b>3.79</b> 0.35
	30 0.75	<b>0.97</b> 0.06	<b>1.62</b> 0.09	<b>2.26</b> 0.12	<b>2.90</b> 0.15	<b>3.55</b> 0.18	<b>4.19</b> 0.21	<b>4.83</b> 0.24
	36 0.90	<b>1.18</b> 0.11	<b>1.97</b> 0.18	<b>2.75</b> 0.26	<b>3.53</b> 0.33	<b>4.31</b> 0.40	<b>5.10</b> 0.47	<b>5.88</b> 0.55
	42 1.05	<b>1.39</b> 0.13	<b>2.31</b> 0.22	<b>3.24</b> 0.30	<b>4.16</b> 0.39	<b>5.08</b> 0.47	<b>6.00</b> 0.56	<b>6.92</b> 0.64
	48 1.20	<b>1.60</b> 0.15	<b>2.66</b> 0.25	<b>3.73</b> 0.35	<b>4.79</b> 0.45	<b>5.85</b> 0.54	<b>6.91</b> 0.64	<b>7.97</b> 0.74
	54 1.35	<b>1.81</b> 0.17	<b>3.01</b> 0.28	<b>4.21</b> 0.39	<b>5.42</b> 0.50	<b>6.62</b> 0.62	<b>7.82</b> 0.73	<b>9.02</b> 0.84
	60 1.50	<b>2.09</b> 0.19	<b>3.47</b> 0.32	<b>4.85</b> 0.45	<b>6.23</b> 0.58	<b>7.62</b> 0.71	<b>9.00</b> 0.84	<b>10.38</b> 0.97
	66 1.65	<b>2.30</b> 0.21	<b>3.82</b> 0.36	<b>5.34</b> 0.50	<b>6.86</b> 0.64	<b>8.38</b> 0.78	<b>9.90</b> 0.92	<b>11.43</b> 1.06
	72 1.80	<b>2.51</b> 0.23	<b>4.17</b> 0.39	<b>5.83</b> 0.54	<b>7.49</b> 0.70	<b>9.15</b> 0.85	<b>10.81</b> 1.01	<b>12.47</b> 1.16
	78 1.95	<b>2.72</b> 0.25	<b>4.52</b> 0.42	<b>6.32</b> 0.59	<b>8.12</b> 0.75	<b>9.92</b> 0.92	<b>11.72</b> 1.09	<b>13.52</b> 1.26
	84 2.10	<b>2.93</b> 0.27	<b>4.87</b> 0.45	<b>6.81</b> 0.63	<b>8.75</b> 0.81	<b>10.69</b> 0.99	<b>12.62</b> 1.17	<b>14.56</b> 1.35
	90 2.25	<b>3.14</b> 0.29	<b>5.22</b> 0.49	<b>7.30</b> 0.68	<b>9.37</b> 0.87	<b>11.45</b> 1.07	<b>13.53</b> 1.26	<b>15.61</b> 1.45
	96 2.40	<b>3.41</b> 0.32	<b>5.67</b> 0.53	<b>7.93</b> 0.74	<b>10.19</b> 0.95	<b>12.45</b> 1.16	<b>14.71</b> 1.37	<b>16.97</b> 1.58

## PRESSURE DROP

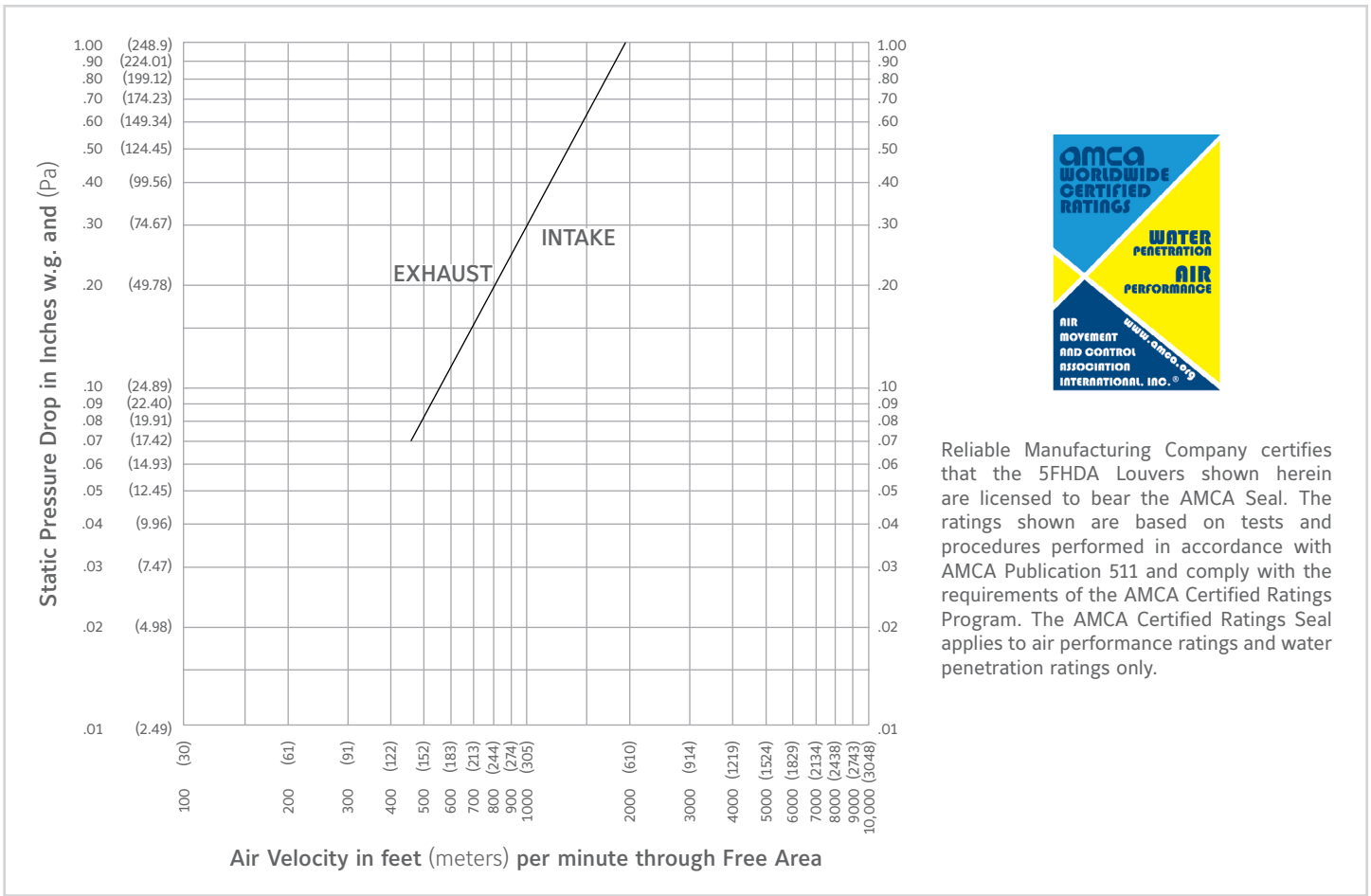

Reliable Manufacturing Company certifies that the 5FHDA Louvers shown herein are licensed to bear the AMCA Seal. The ratings shown are based on tests and procedures performed in accordance with AMCA Publication 511 and comply with the requirements of the AMCA Certified Ratings Program. The AMCA Certified Ratings Seal applies to air performance ratings and water penetration ratings only.

## WATER PENETRATION

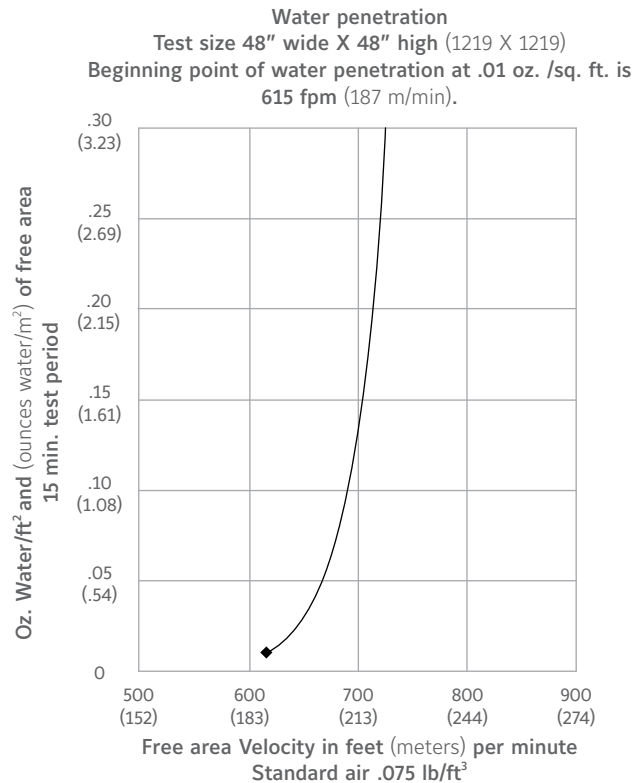

# INSTALLATION DETAILS

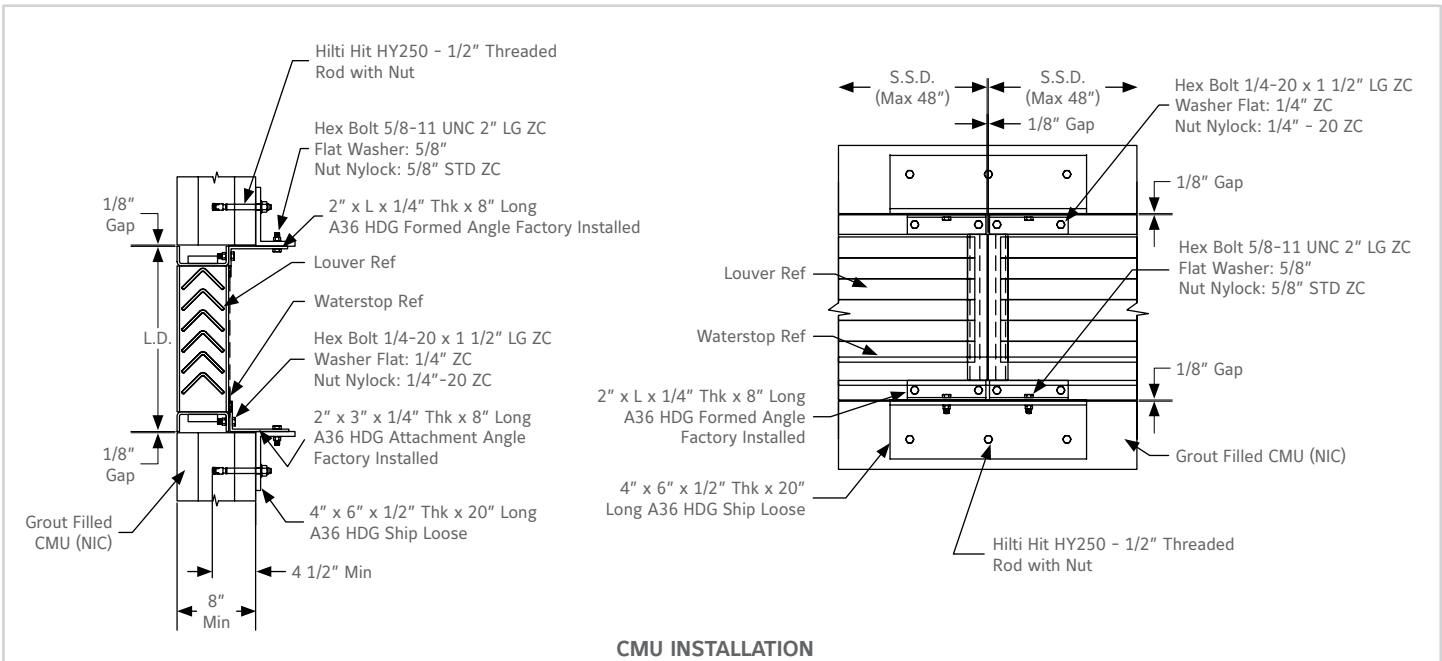
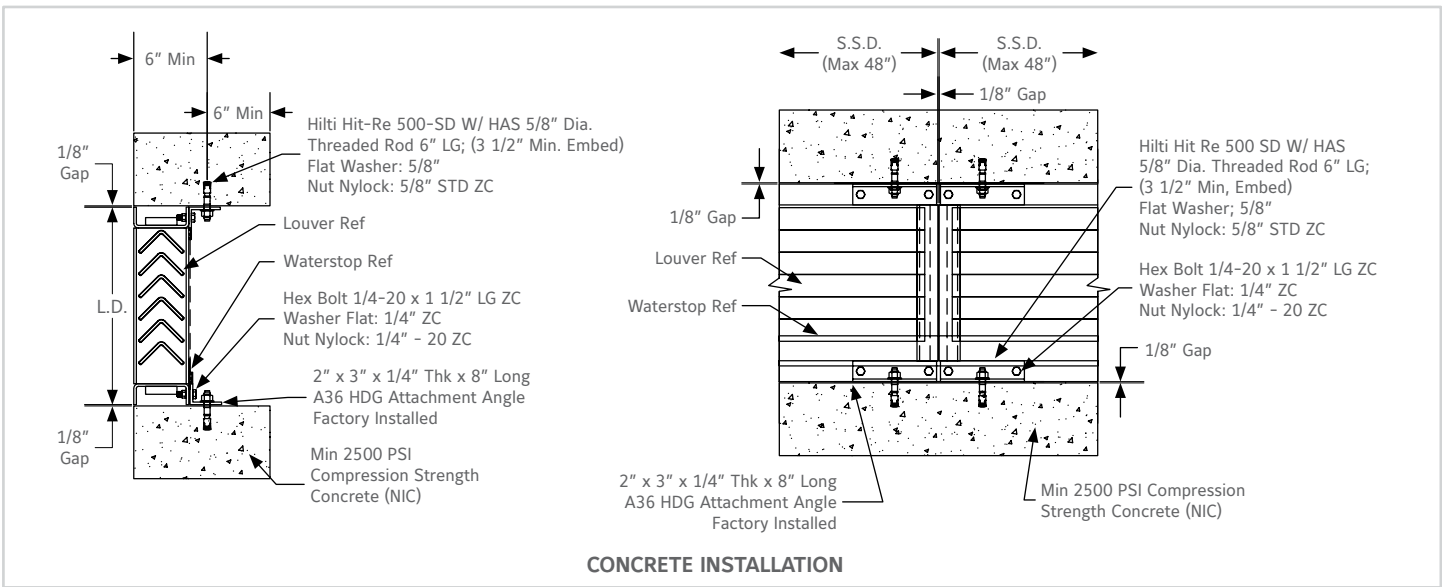
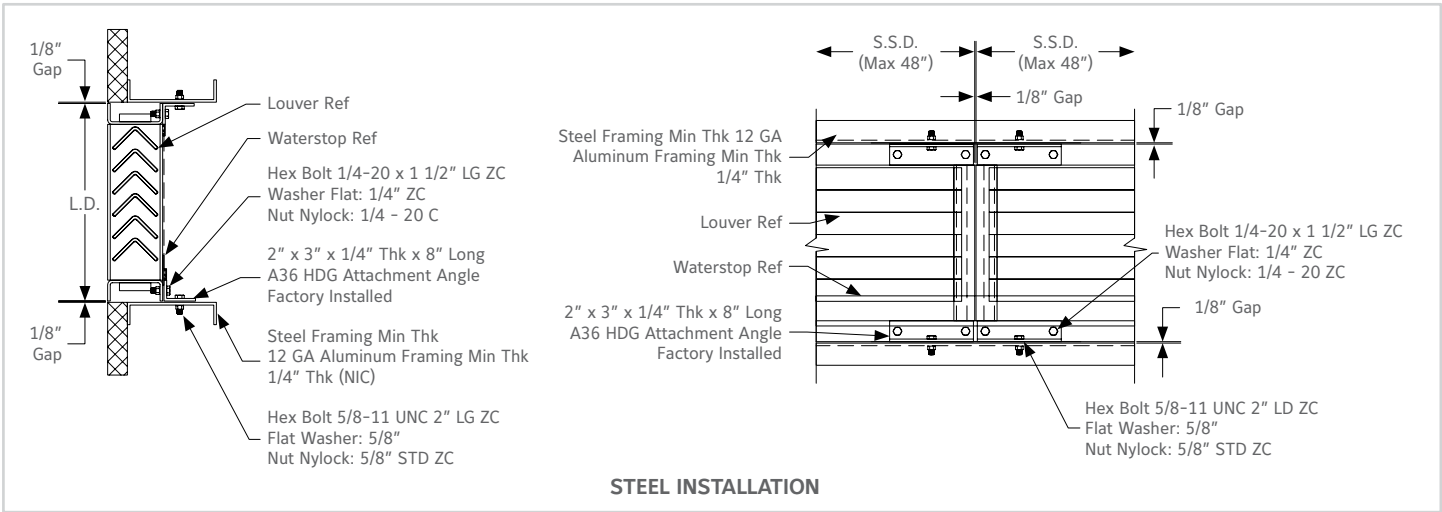

## CONSTRUCTION INFORMATION

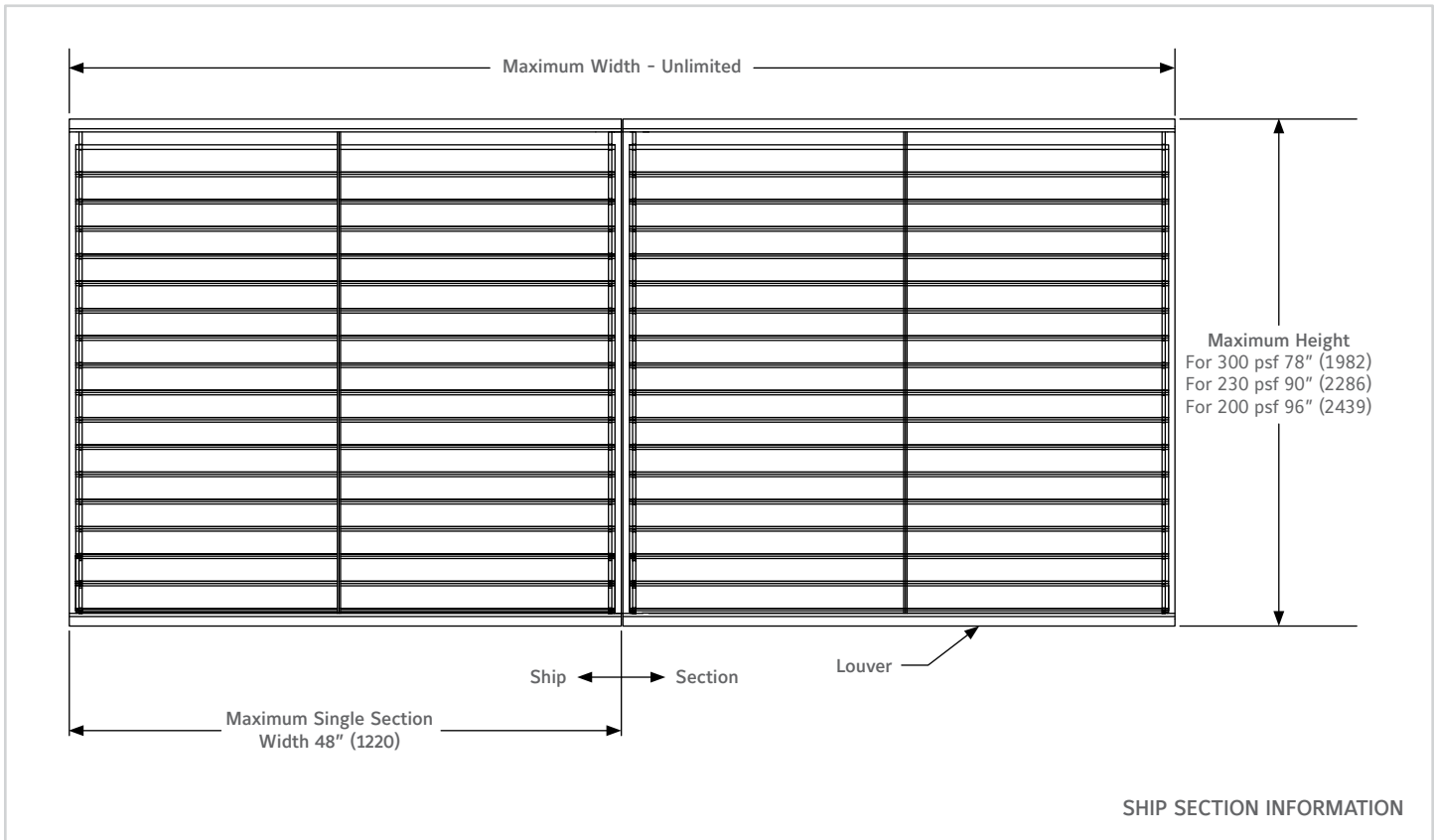

1. Reference separate installation instruction sheets for installation details. It is the responsibility of the installing contractor to properly install the louvers per the appropriate detail.
2. On special orders, Reliable may provide submittal and/or shop drawings. Reference these drawings for additional installation information.
3. Louvers wider than the maximum single section width will be shipped in multiple sections and will require field assembly. Field assembly is not by Reliable.

### LINKS TO IMPORTANT DOCUMENTS

#### Document Title

Finishes and Color Guide

Limited Warranty Document

**RELIABLE**

1300 Enterprise Road, P.O. Box  
580, Geneva, Alabama 36340  
Tel: 334-684-3621  
Tel: 800-624-3914  
Fax: 800-508-1469