

# 3RRGV

## Wind-Driven Rain Resistant Stationary Louver

Extruded Aluminum



### APPLICATION

The 3RRGV is a 3" deep extruded aluminum louver with closely spaced vertical blades that prevent the penetration of wind-driven rain. This louver is designed with exceptional protection against wind-driven rain under severe conditions.

### STANDARD CONSTRUCTION

<b>Frame</b>	3" (76) deep, 6063T6 extruded aluminum with .073" (1.9) nominal wall thickness.
<b>Blades</b>	6063T5 extruded aluminum .040" (1) nominal wall thickness. Blades are mounted vertically and spaced approximately 3/4" (19) center to center.
<b>Screen</b>	1/2" x .063" (13 x 1.6) square mesh aluminum bird screen in removable frame. Screen adds approximately 1/2" (13) to louver depth.
<b>Extended Sill</b>	.080" (2.0) formed aluminum with end dams.
<b>Finish</b>	Mill.
<b>Minimum Size</b>	12"w x 12"h (305 x 305).
<b>Approximate Shipping Weight</b>	5 lbs. per sq. ft. (24 kg/m <sup>2</sup> ).
<b>Maximum Single Section Size</b>	Shall be 48" x 96" (1219 x 2438). Lifting lugs provided on louvers 48" x 72" (1219 x 1829) and larger. Louvers larger than the maximum factory assembly size will require field assembly of smaller sections.

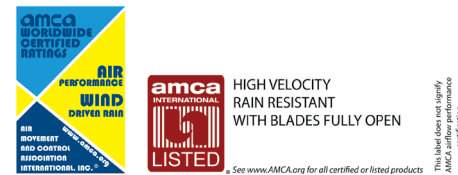
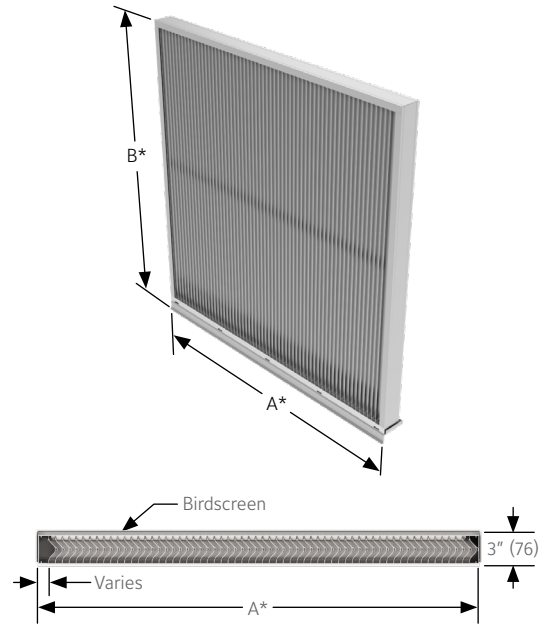

### FEATURES

- AMCA 550 Listed Louver
- 46% Free Area
- Closely spaced vertical blades prevent the penetration of wind-driven rain, reducing damage and additional operating expenses
- Published performance ratings based on testing in accordance with AMCA Publication 500L
- Excellent pressure drop performance
- Aluminum construction for low maintenance and high resistance to corrosion
- All welded construction
- Visible mullion construction. Hidden mullions and continuous blade construction are not available

### VARIATIONS

Variations to the basic design of these louvers are available at additional cost. They include:

- Filter racks
- A variety of bird and insect screens
- Selection of finishes: baked enamel (modified fluoropolymer), epoxy, PVDF, Pearledize 50 & 70, prime coat, clear and color anodize. (Some variation in anodize color consistency is possible)

All variations are available at additional cost.

Consult Reliable for other special requirements.

### FRAME CONSTRUCTION

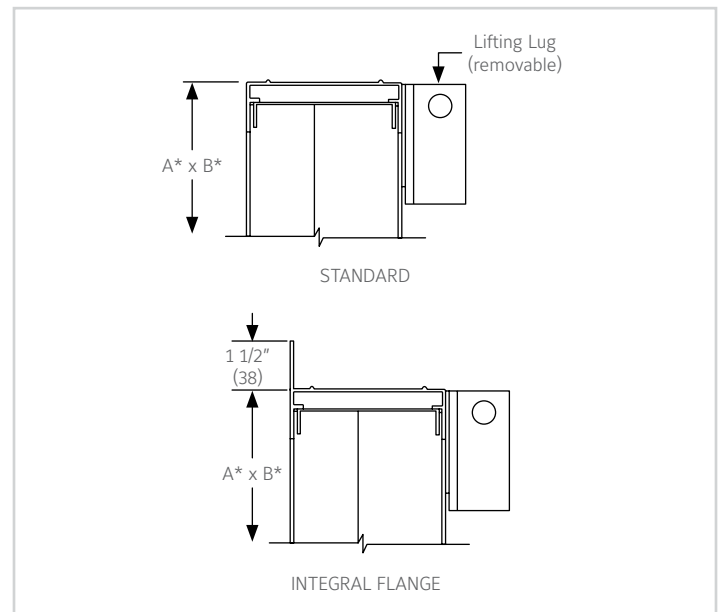

Note:

- Dimensions in inches, parenthesis ( ) indicate millimeters.
- Units can be furnished actual size or with size deducts.

## FREE AREA GUIDE

Free Area Guide shows free area in ft<sup>2</sup> and m<sup>2</sup> for various sizes of 3RRGV.

		Width – Inches and Meters							
		12 0.30	18 0.45	24 0.60	30 0.75	36 0.90	42 1.05	48 1.20	
Height – Inches and Meters	12 0.30	<b>0.22</b> 0.02	<b>0.37</b> 0.03	<b>0.52</b> 0.05	<b>0.67</b> 0.06	<b>0.82</b> 0.08	<b>0.97</b> 0.09	<b>1.12</b> 0.10	
	18 0.45	<b>0.43</b> 0.04	<b>0.72</b> 0.07	<b>1.00</b> 0.09	<b>1.29</b> 0.12	<b>1.57</b> 0.15	<b>1.86</b> 0.17	<b>2.15</b> 0.20	
	24 0.60	<b>0.64</b> 0.06	<b>1.06</b> 0.10	<b>1.48</b> 0.14	<b>1.91</b> 0.18	<b>2.33</b> 0.22	<b>2.75</b> 0.26	<b>3.18</b> 0.30	
	30 0.75	<b>0.84</b> 0.08	<b>1.40</b> 0.13	<b>1.96</b> 0.18	<b>2.52</b> 0.23	<b>3.08</b> 0.29	<b>3.64</b> 0.34	<b>4.20</b> 0.39	
	36 0.90	<b>1.05</b> 0.10	<b>1.74</b> 0.16	<b>2.44</b> 0.23	<b>3.14</b> 0.29	<b>3.84</b> 0.36	<b>4.54</b> 0.42	<b>5.23</b> 0.49	
	42 1.05	<b>1.25</b> 0.12	<b>2.09</b> 0.19	<b>2.92</b> 0.27	<b>3.76</b> 0.35	<b>4.59</b> 0.40	<b>5.43</b> 0.50	<b>6.26</b> 0.50	
	48 1.20	<b>1.46</b> 0.14	<b>2.43</b> 0.23	<b>3.40</b> 0.32	<b>4.38</b> 0.41	<b>5.35</b> 0.50	<b>6.32</b> 0.59	<b>7.29</b> 0.68	
	54 1.35	<b>1.66</b> 0.15	<b>2.77</b> 0.26	<b>3.88</b> 0.36	<b>4.99</b> 0.46	<b>6.10</b> 0.57	<b>7.21</b> 0.67	<b>8.32</b> 0.77	
	60 1.50	<b>1.87</b> 0.17	<b>3.12</b> 0.29	<b>4.36</b> 0.41	<b>5.61</b> 0.52	<b>6.86</b> 0.64	<b>8.11</b> 0.75	<b>9.35</b> 0.87	
	66 1.65	<b>2.08</b> 0.19	<b>3.46</b> 0.32	<b>4.85</b> 0.45	<b>6.23</b> 0.58	<b>7.61</b> 0.71	<b>9.00</b> 0.84	<b>10.38</b> 0.97	
	72 1.80	<b>2.28</b> 0.21	<b>3.80</b> 0.35	<b>5.33</b> 0.50	<b>6.85</b> 0.64	<b>8.37</b> 0.78	<b>9.89</b> 0.92	<b>11.41</b> 1.06	
	78 1.95	<b>2.49</b> 0.23	<b>4.15</b> 0.39	<b>5.81</b> 0.54	<b>7.47</b> 0.69	<b>9.12</b> 0.85	<b>10.78</b> 1.00	<b>12.44</b> 1.16	
	84 2.10	<b>2.69</b> 0.25	<b>4.49</b> 0.42	<b>6.29</b> 0.58	<b>8.08</b> 0.75	<b>9.88</b> 0.92	<b>11.68</b> 1.09	<b>13.47</b> 1.25	
	90 2.25	<b>2.90</b> 0.27	<b>4.83</b> 0.45	<b>6.77</b> 0.63	<b>8.70</b> 0.81	<b>10.64</b> 0.99	<b>12.57</b> 1.17	<b>14.50</b> 1.35	
	96 2.40	<b>3.11</b> 0.29	<b>5.18</b> 0.48	<b>7.25</b> 0.67	<b>9.32</b> 0.87	<b>11.39</b> 1.06	<b>13.46</b> 1.25	<b>15.53</b> 1.44	



Reliable Products certifies that the louver shown herein is licensed to bear the AMCA Seal. The ratings shown are based on tests and procedures performed in accordance with AMCA Publication 511 and comply with the requirements of the AMCA Certified Ratings Program. The AMCA Certified Ratings Seal applies to air performance ratings and wind driven rain ratings only.

## PRESSURE DROP

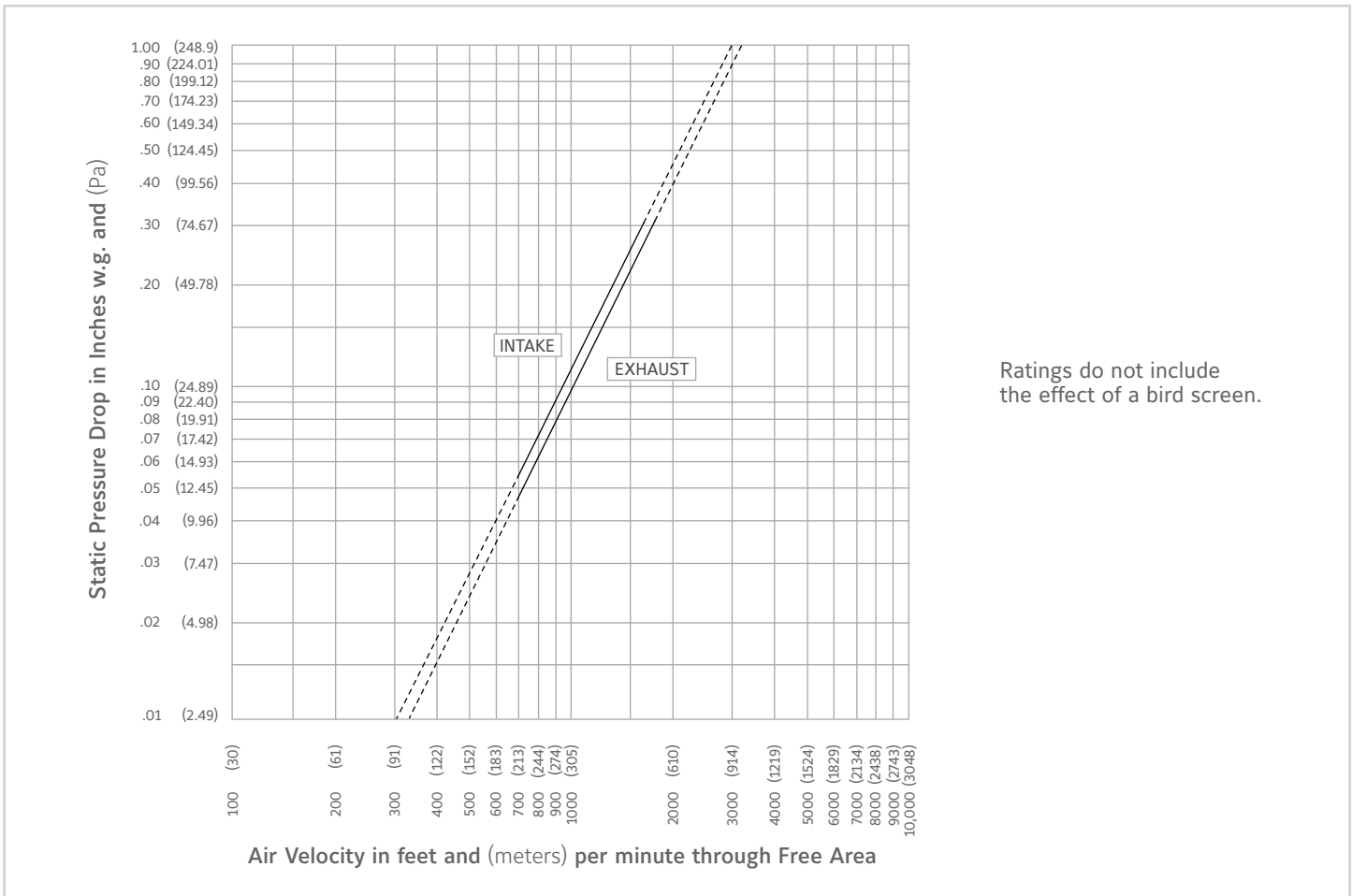

## PERFORMANCE DATA



HIGH VELOCITY  
RAIN RESISTANT  
WITH BLADES FULLY OPEN

See www.AMCA.org for all certified or listed products

Reliable Model 3RRGV  
certification

Reliable certifies that the Reliable Model 3RRGV shown herein is approved to bear the AMCA Listing Label. The ratings shown are based on tests and procedures performed in accordance with AMCA Publications and comply with the requirements of the AMCA Listing Label Program.

The AMCA Listing Label applies to High Velocity Rain Resistant Louvers.

## WIND-DRIVEN RAIN PERFORMANCE

Test size is: 39" x 39" (.99 x .99) core area, 41" x 41" (1.04 x 1.04) nominal. Free Area of test louver is 5.18 ft.<sup>2</sup> (.48m<sup>2</sup>).

Wind Velocity mph (kph)	Rain Fall Rate In./hr. (mm/hr.)	Core Velocity fpm (m/s <sup>1</sup> )	Airflow cfm (m <sup>3</sup> /min)	Free Area Velocity <sub>2</sub> fpm (m/sec.)	Effectiveness Ratio	Class <sub>3, 4</sub>	Discharge Loss Class <sub>5</sub> Intake
29 (46.4)	3 (76)	967 (5)	10,412 (294)	2,010 (10.0)	100%	A	1
50 (80.5)	8 (203)	974 (5)	10,484 (296)	2,024 (10.1)	100%	A	1

### NOTES:

- Core area is the open area of the louver face (face area less louver frames). Core Velocity is the airflow velocity through the Core Area of the louver. 5 m/s is the maximum core velocity utilized in this test.
- Free Area of test size is calculated per AMCA standard 500-L.
- Wind-Driven Rain Penetration Classes:
 

Class	Effectiveness
A	1 to .99
B	0.989 to .095
C	0.949 to 0.80
D	Below 0.8
- The 3RRGV provides class A performance at all velocities up to and including 5 m/s core velocity.

- Discharge Loss Coefficient is calculated by dividing a louvers' actual airflow rate vs. a theoretical airflow for the opening. It provides an indication of the louvers' airflow characteristics.

Discharge Loss Classes:

**Class Discharge Loss Coefficient**

- |   |                 |
|---|-----------------|
| 1 | 0.4 and above   |
| 2 | 0.3 to 0.399    |
| 3 | 0.2 to 0.299    |
| 4 | 0.199 and below |

(The higher the coefficient, the less resistance to airflow.)

## TYPICAL INSTALLATION DETAILS

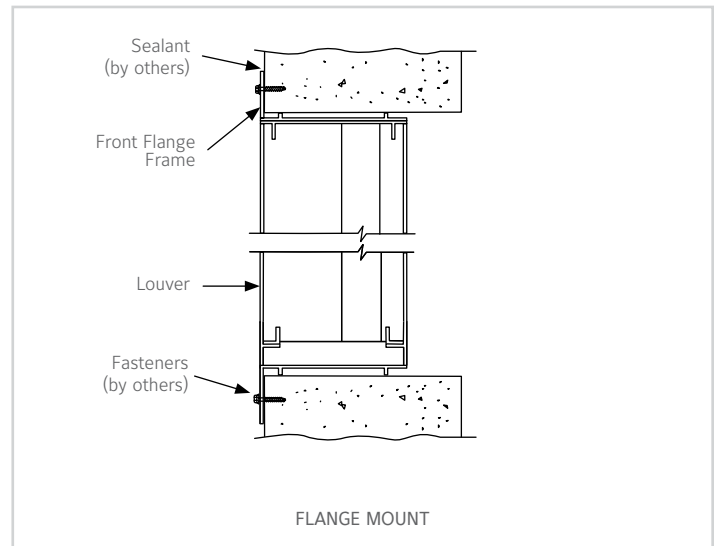
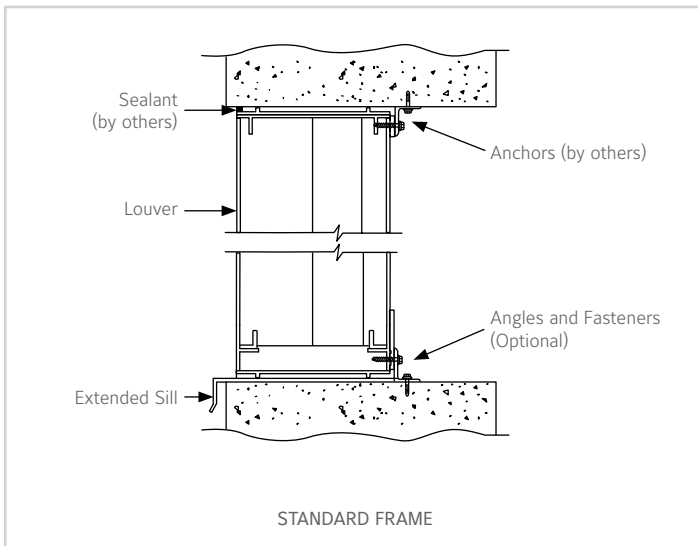

Options available at additional cost.

## SUGGESTED SPECIFICATION

Furnish and install louvers as hereinafter specified where shown on plans or as described in schedules. Louvers shall possess stationary vertical blades designed to prevent the penetration of wind-driven rain. Louver blades shall be contained within a 3" (76) frame. Louver components (heads, jambs, sill and blades) shall be factory assembled by the louver manufacturer. Louver sizes too large for shipping shall be built up by the contractor from factory assembled louver sections to provide overall sizes required. Louver design shall limit single section sizes to 48" x 96" (1219 x 2438) and shall withstand a wind load of 30 lbs. per sq. ft. (1.44 kPa) (equivalent of a 110 mph wind [177 kph] - specifier may substitute any loading required).

Louvers shall be Reliable Model 3RRVG extruded 6063T6 aluminum alloy construction as follows:

Frame: .073" (1.9) wall thickness, caulking surfaces provided.

Blades: .040" (1) wall thickness, installed vertically on approximately .75" (19) centers.

Screen: .050" x .063" (13 x 1.6) square mesh aluminum bird screen in removable frame.

Finish: Select finish specification from Reliable Finishes Brochure.

## LINKS TO IMPORTANT DOCUMENTS

### Document Title

Finishes and Color Guide

Limited Warranty Document

**RELIABLE**

1300 Enterprise Road, P.O. Box  
580, Geneva, Alabama 36340  
Tel: 334-684-3621  
Tel: 800-624-3914  
Fax: 800-508-1469