

# CLIP ANGLE

## Installation Guide



### ASSEMBLY PROCEDURE:

1. If you ordered installation angles, it will come in a kit that includes clip angles, fasteners etc.,
2. Refer to shop drawings to determine set back of clip angles on jamb/head/sill in relation to wall.(If shop drawings were requested).
3. Measure set back distance of clip angles from wall and drill holes into wall as needed.
4. Attach clip angles to wall with substrate fasteners. (Substrate fasteners not provided by Reliable).
5. Place louver section into opening.
6. Shim around louver perimeter to provide proper clearance/deduct as mentioned in shop drawings. (If shop drawings were requested)
7. Once clearance specifications are met, use holes provided in clip angle to drill pilot holes in jamb.
8. Fasten clip angles to jambs with fasteners as provided by Reliable (Ship loose kit).
9. Refer to shop drawings to attach clips at HVBS & mullion supports (If shop drawings were requested).
10. Notch the continuous Clip angle as needed to fit them in between the supports.
11. If extended sill is ordered, please place a bead of caulk between the opening & sill (Caulk supplied by others).

### INSTALLATION DETAILS

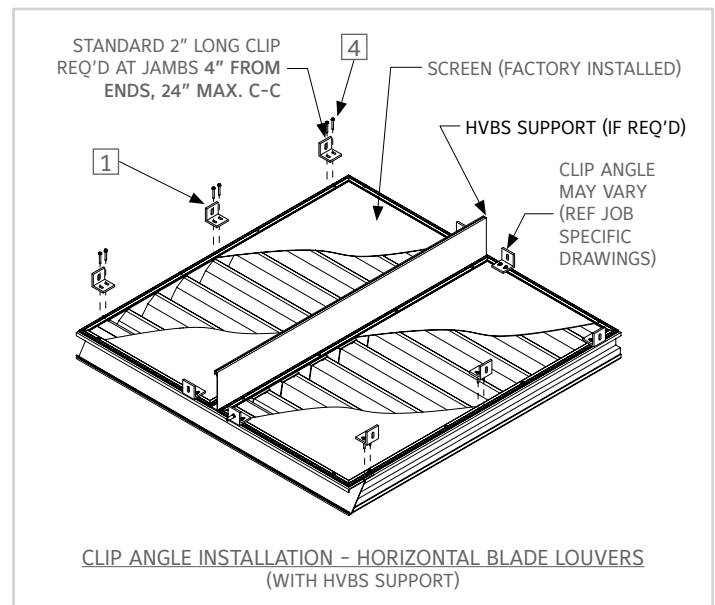
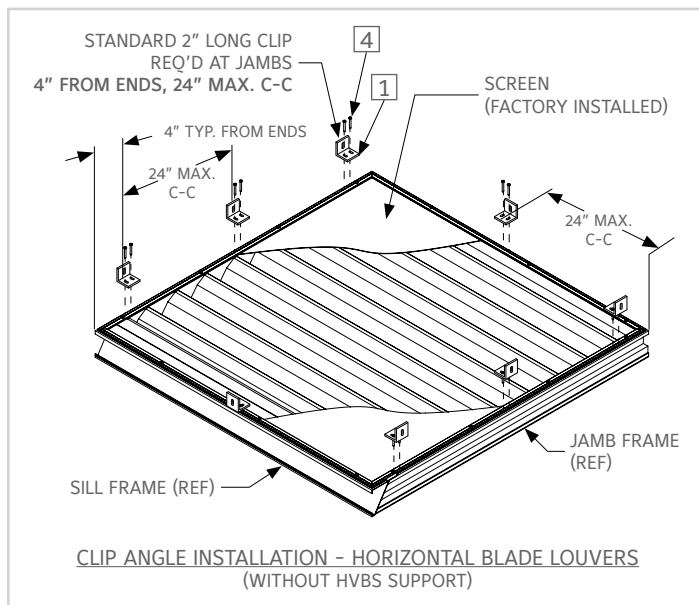

ITEM #	DESCRIPTION	QTY.	PART #	MATERIAL
<b>SHIP LOOSE PARTS (SQUARE BALLOONS)</b>				
1	CLIP ANG 2 X 2 X 1/4 X 2" LG W/2 .25 X .63 SLOTS	-	360502443	6063-T6 ALUM
2	CLIP ANG 2 X 2 X 1/4 (6" LG PUNCHED)	-	360502825	6063-T6 ALUM
3	ANG 2 X 2 X .25 X CONT.	-	341396M00	6063-T6 ALUM
4	SCR 10 X 1.5 HWH TEK	-	380430830	410/ZC

**REFERENCE IMAGES**

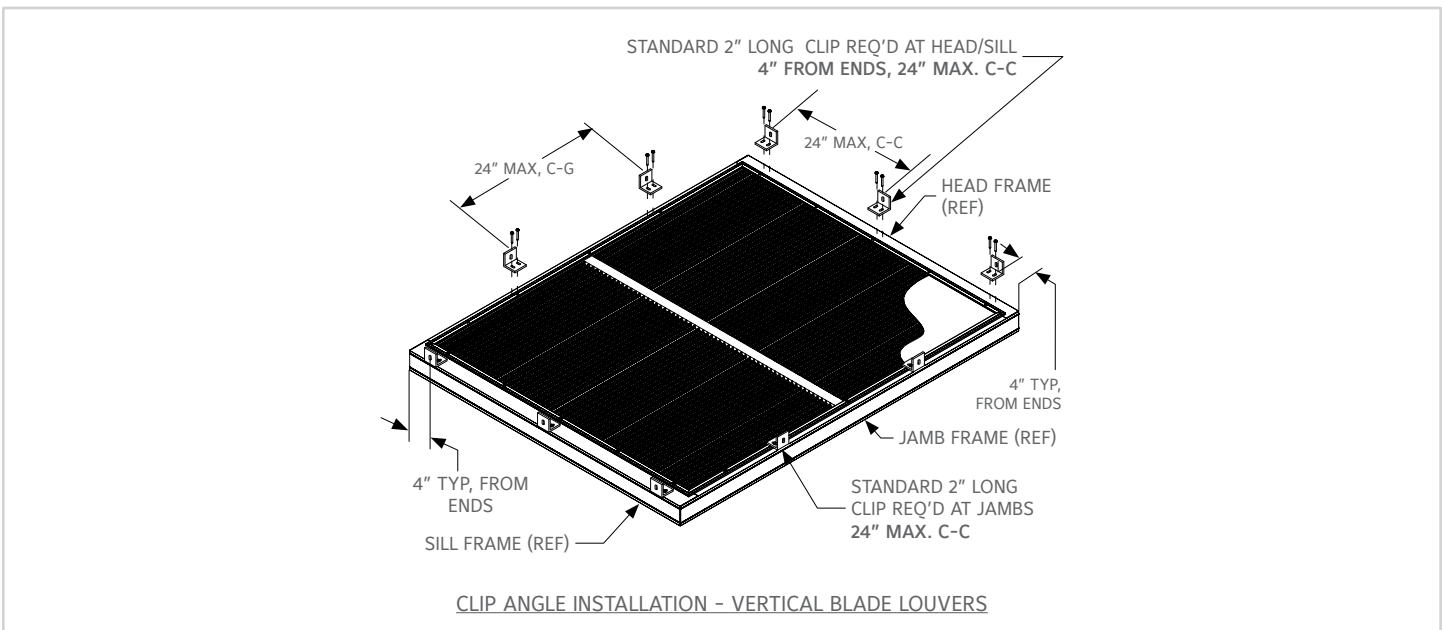
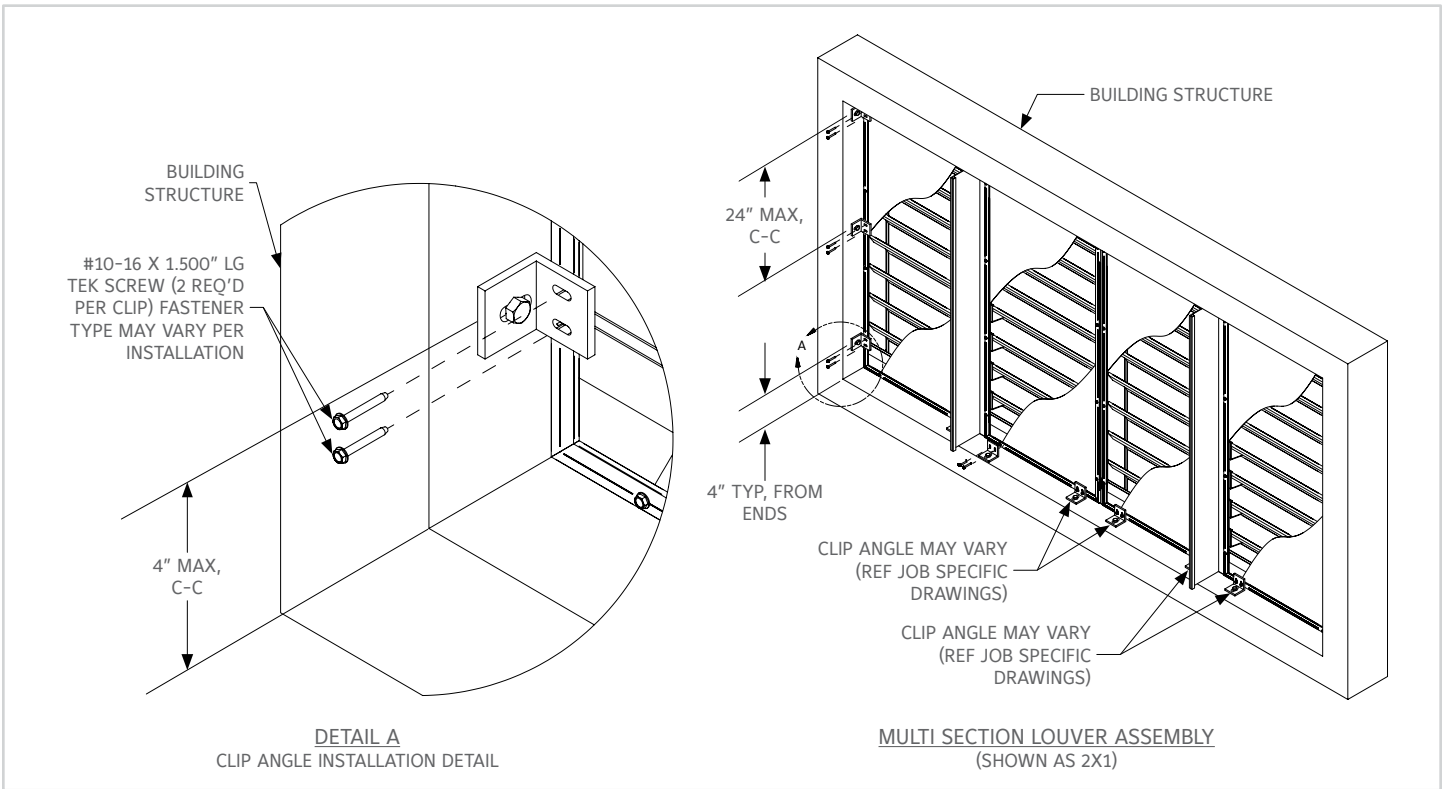

**REFERENCE IMAGES**

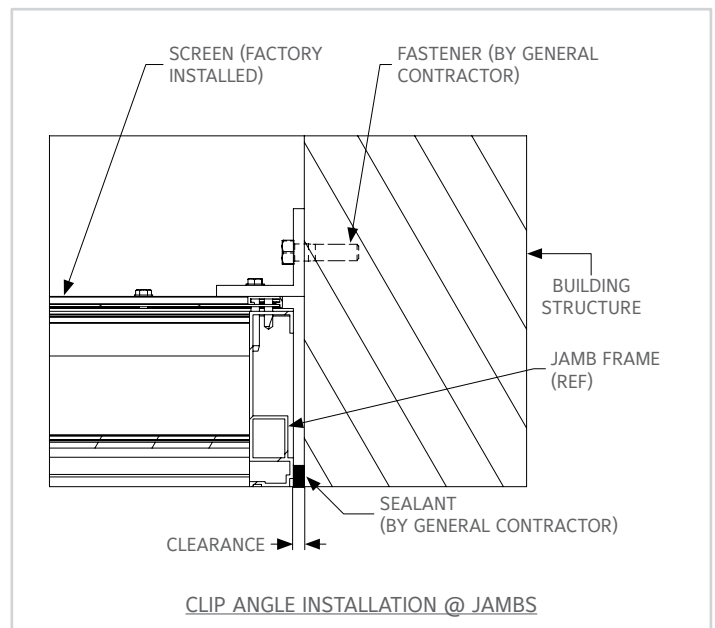
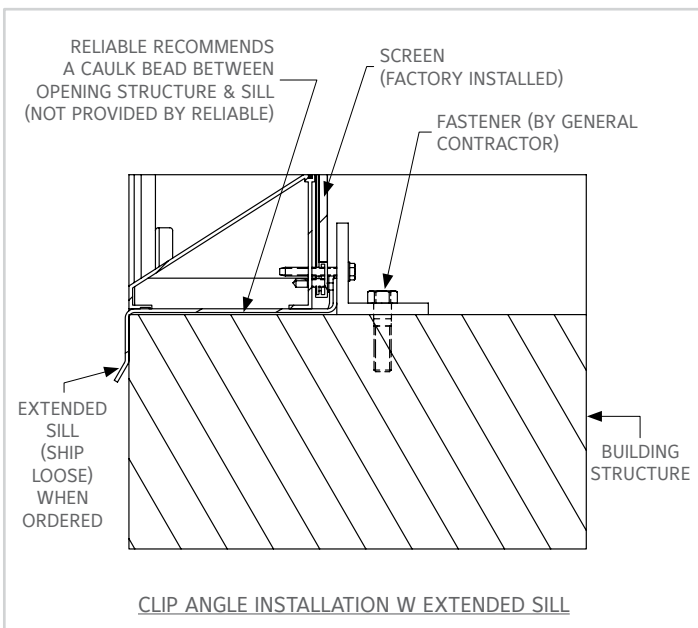
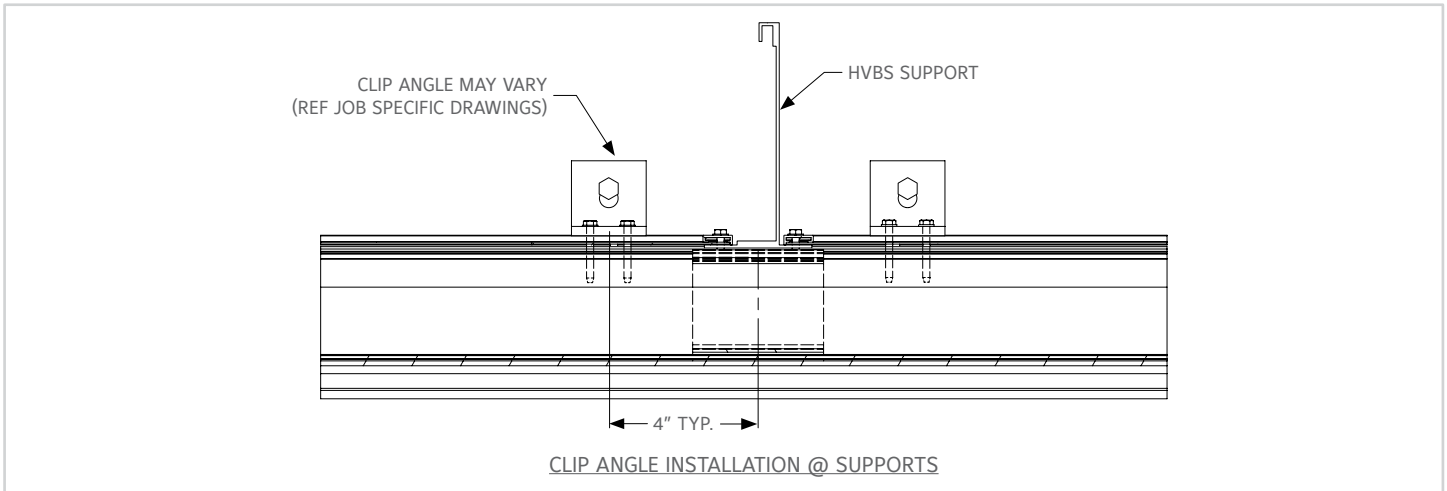
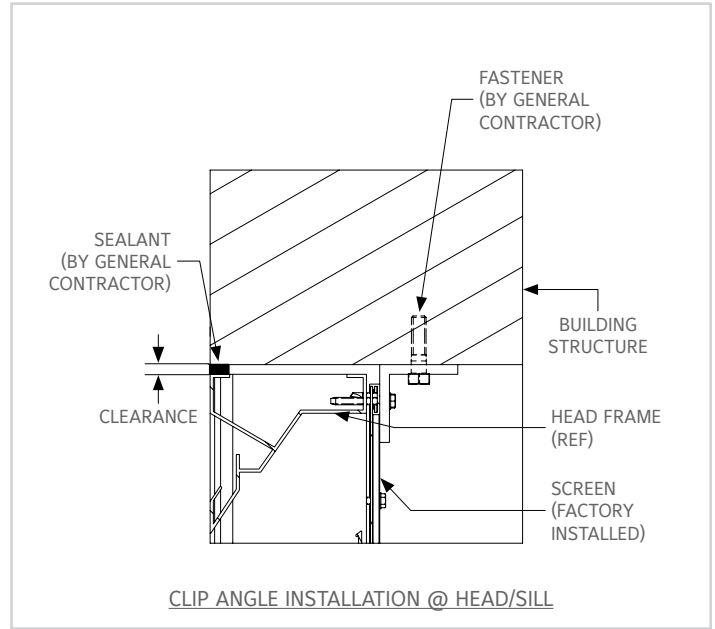
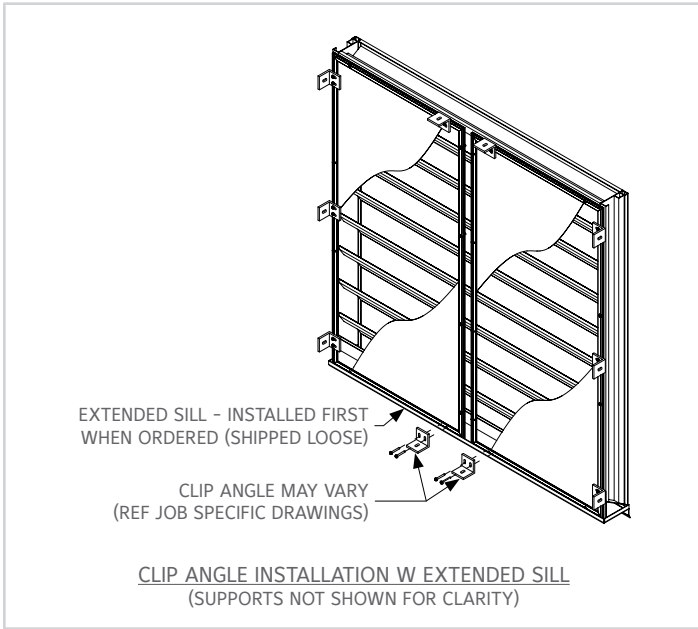

# CONTINUOUS CLIP ANGLE INSTALLATION DETAIL

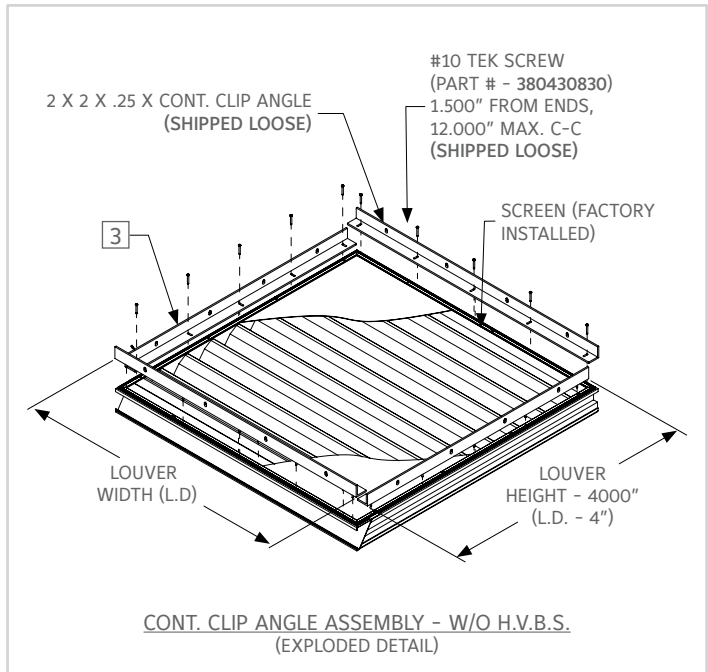
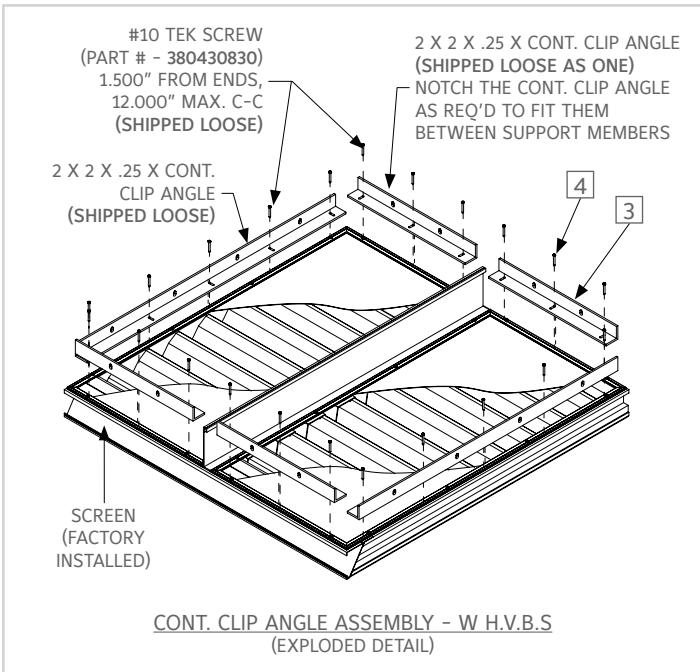
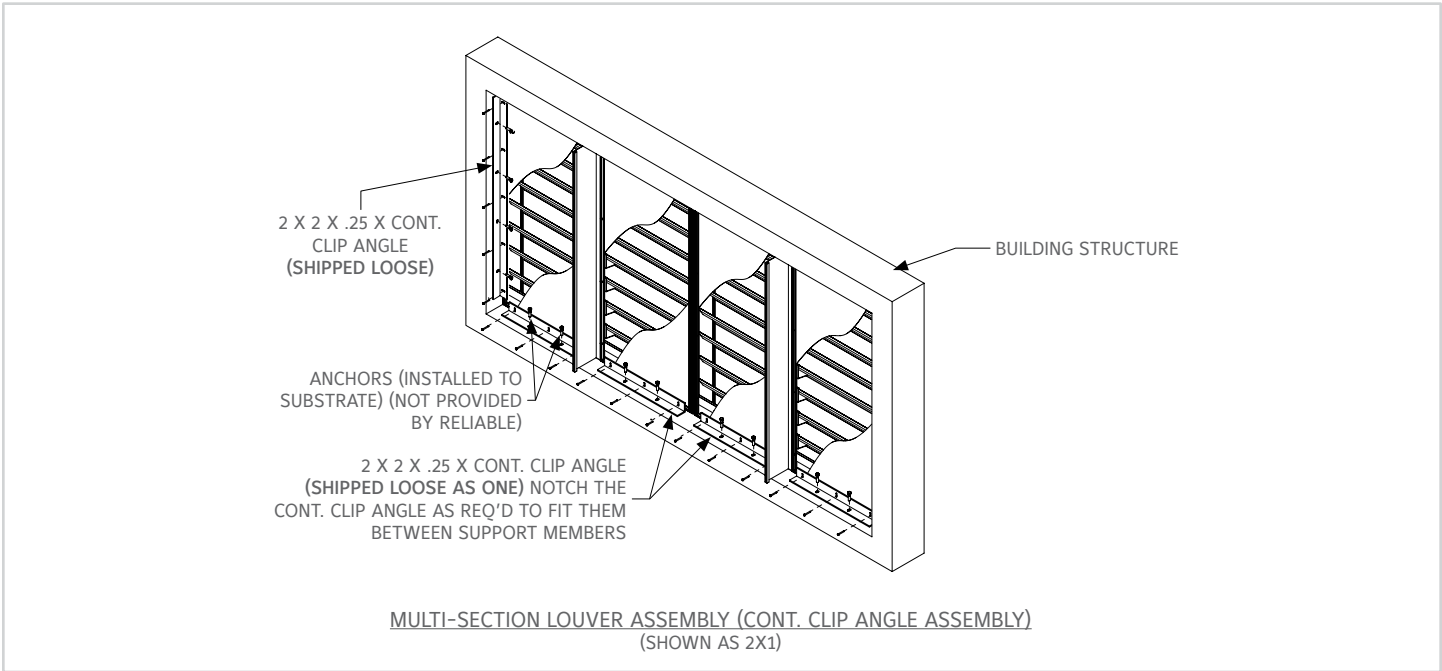

1300 Enterprise Road, P.O. Box  
580, Geneva, Alabama 36340  
Tel: 334-684-3621  
Tel: 800-624-3914  
Fax: 800-508-1469  
Website: [www.reliablelouvers.com](http://www.reliablelouvers.com)